

CRE3000 SUSPENSION SYSTEM

OWNER'S MANUAL

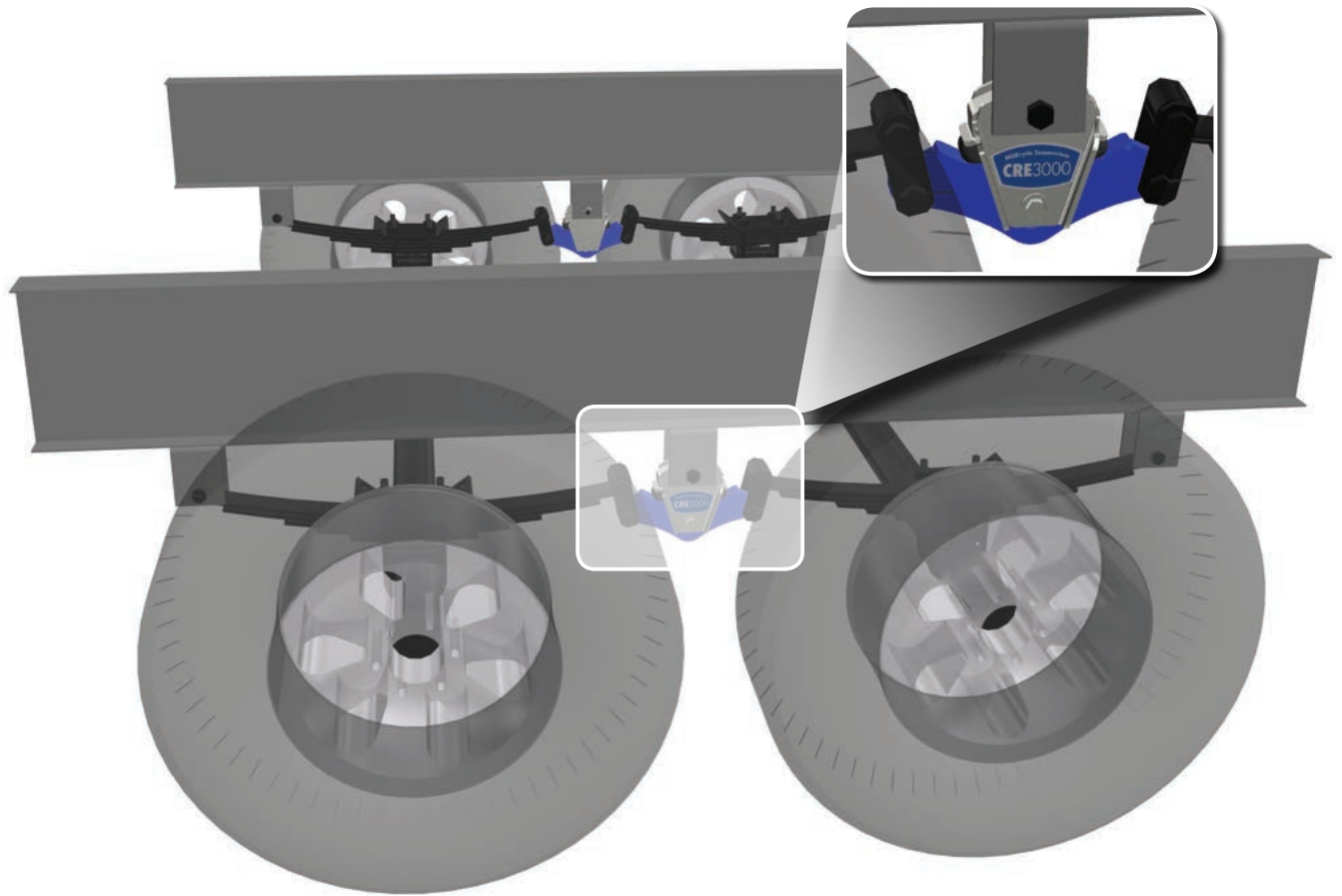

Above. Beyond. Always.

CRE3000 SUSPENSION SYSTEM

OWNER'S MANUAL

CONTENTS

Introduction	2
Parts List	3
Tripe Axle Setup	4
Rubber Shear Spring Inspection	5
Basic Troubleshooting	6
Warranty	7



Above. Beyond. Always.



INTRODUCTION

Your recreational vehicle has been equipped with the MORryde **CRE3000** Suspension System. The MORryde system is located between the tandem axles on your trailer, replacing the steel equalizer (see diagram below). This system is uniquely engineered to work in concert with your steel leaf spring suspension to improve overall suspension performance.

At the heart of your MORryde system are MORryde's rubber springs that have been a mainstay in the recreational vehicle market for over 40 years. This system has been engineered specifically for your trailer using the rubber springs' ability to isolate and absorb road shock and increase your trailer's overall dynamic axle travel. The combination of the MORryde rubber equalizer working in concert with your trailer's leaf springs will greatly enhance your suspension system's ability to deal with today's rough roads. This means you will experience:

- **Smoother towing than with a conventional equalizer and leaf springs**
- **Better protection of your trailer from damaging road shock**

This manual will outline basic troubleshooting and check procedures for your MORryde Suspension System. Service manuals and instructions will be provided with replacement parts in the unlikely event that service is required.

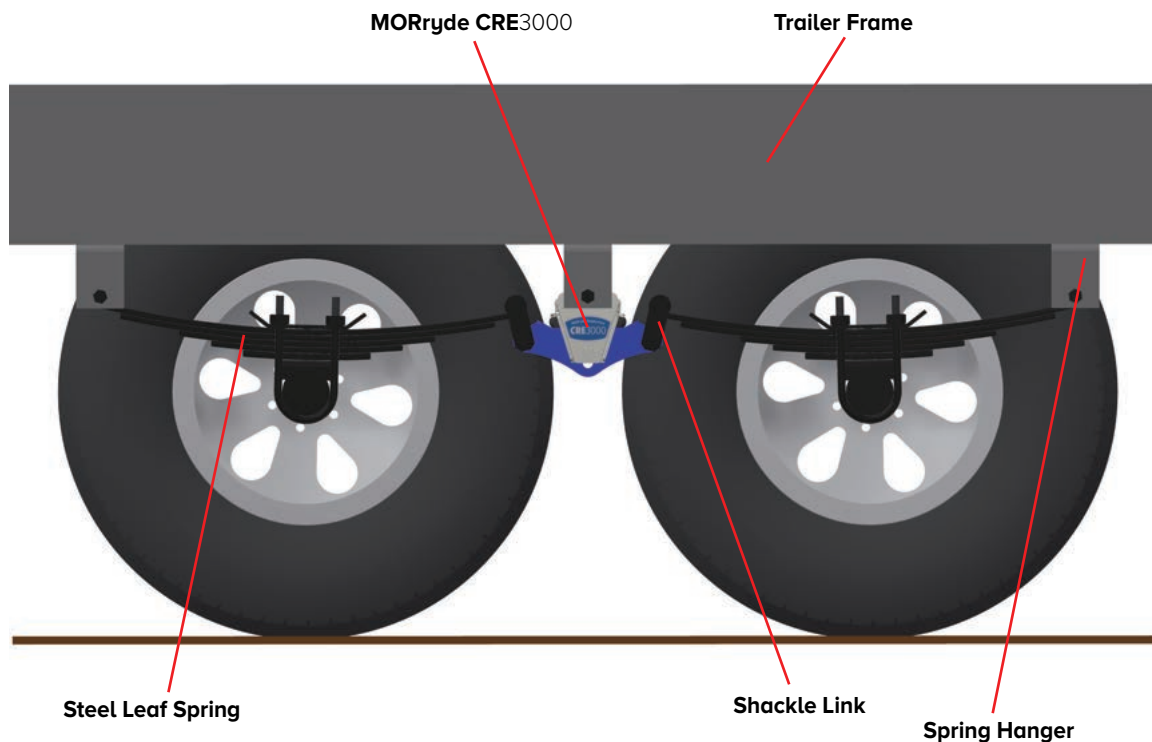

PARTS LIST:

1. Equalizer Beam
2. Rubber Compression Spring
3. Spring Carrier
4. Plastic Glide Pad
5. Bronze Bushing
6. Hex Coupler Nut
7. Washer
8. Bolt



ADDITIONAL PARTS LIST

9. Control Beam Arm



Above. Beyond. Always.

TRIPLE AXLE SETUP

The CRE assembly that has the Control Beam Arm **ALWAYS** gets installed between the front axle and the center axle.

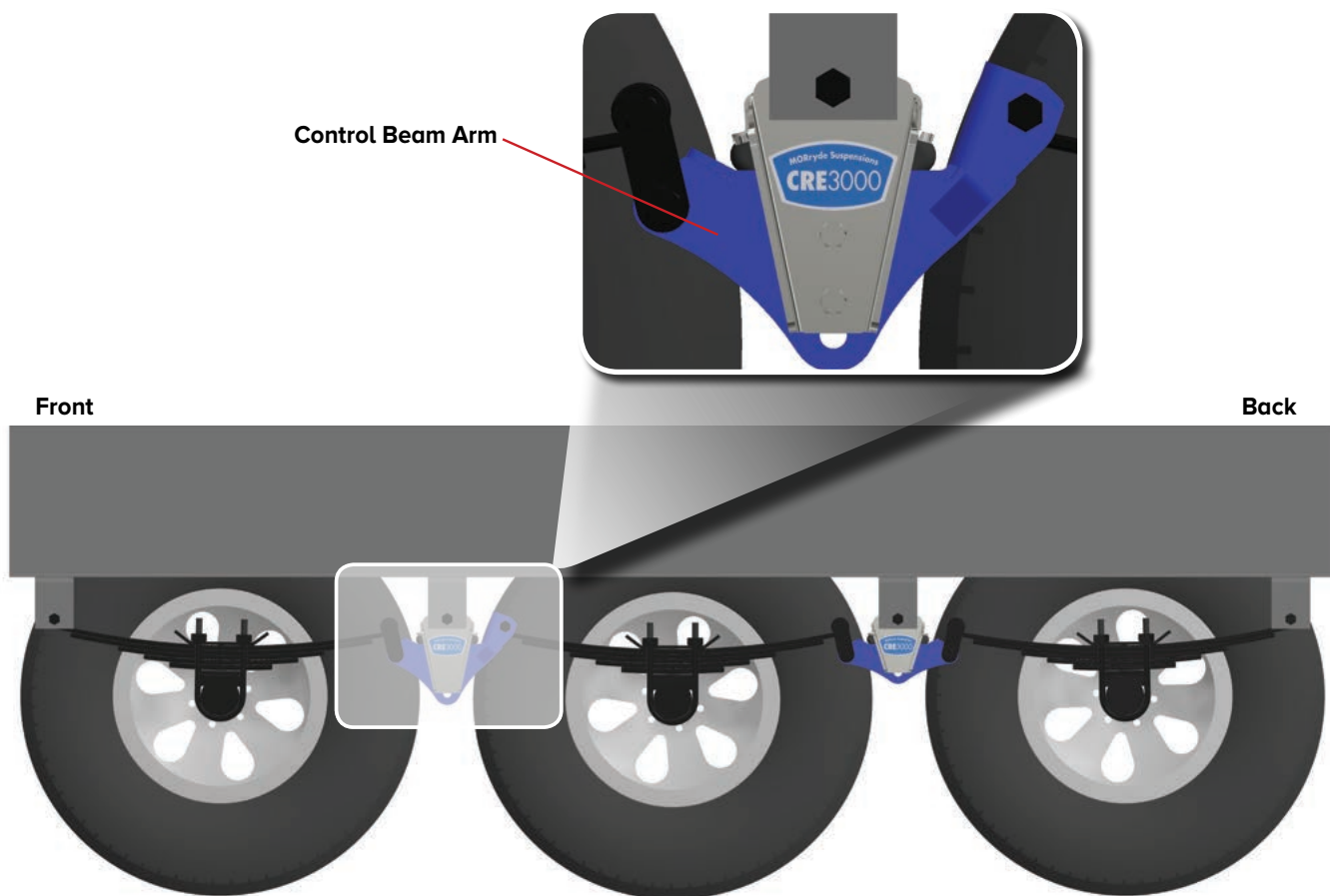

RUBBER SHEAR SPRING INSPECTION

The rubber springs (Item #2 in Parts Listing) should be periodically inspected for deterioration. Figure 1 shows a rubber spring in good condition. If the tabs that protrude from either side of the Spring Carrier (Item #3 in Parts Listing) are touching the top of the Beam Arm (Item #1 in Parts Listing) as shown below (figure 2), the spring rate of the spring has been affected and the equalizer should be replaced.

NOTE: It is normal to see rubber spring weather checking, which is small surface cracks in the rubber. Weather checking does not require an equalizer to be replaced. It is also common to see minor tearing or fretting of the rubber around the edges.

figure 1



CRE3000 with rubber spring in good condition shown at design load

figure 2



CRE3000 with rubber spring worn out shown at design load



Above. Beyond. Always.

BASIC TROUBLESHOOTING

PROBLEM	CAUSE	REMEDY
Excessive Tire Wear	Axle alignment: <ul style="list-style-type: none"> • Improper tire pressure* • Tires out of balance • Improper brake adjustment 	Align axles <ul style="list-style-type: none"> • Adjust air pressure* • Balance tires • Adjust brakes
Rough Ride	<ul style="list-style-type: none"> • Torn rubber spring • Trailer is not level front to back 	<ul style="list-style-type: none"> • Replace the CRE3000 equalizer • Adjust pin box height to level out trailer
Excessive Sway	<ul style="list-style-type: none"> • Improper tire pressure* • Torn rubber spring • Improper hitch weight 	<ul style="list-style-type: none"> • Adjust air pressure* • Replace CRE3000 equalizer • Travel trailers should have 10%-12% hitch weight • 5th wheel trailers should have 20% -25% hitch weight

* According to tire manufacturer specifications, proper tire pressure means inflating tires according to individual wheel weights (as long as a wheel is not overloaded), not necessarily inflating to the maximum pressure as specified on the tire.

If you have any questions, please give us a call at **574-293-1581** or send an email to parts@MORryde.com.

WARRANTY

Please visit www.MORryde.com for warranty information.

At MORryde, we have a passion for solving problems. Whether we're fabricating custom solutions, modifying a commercial chassis, or creating our innovative products, we answer to a wide range of markets and deliver on a variety of needs. At MORryde, it's simply about doing MORE for our customers, and it doesn't stop at the sale. We stand behind our products, believing in quality first, service always. No matter the issue, we'll be the first to respond and the last to be satisfied. In short, we build better — together.



Above. Beyond. Always.

574.293.1581 • MORryde.com •    